

USER GUIDE • GUIDE DE L'UTILISATEUR



HEADSET STAND WITH USB HUB

REGISTER NOW



ENREGISTRER

This product comes with a 1 year limited warranty.

Register this product within 30 days of sale to activate a complimentary 2 year warranty extension and receive free advanced technical support. Learn more and register now.

Ce produit est livré avec une garantie limitée de 1 an.

Enregistrez ce produit dans les 30 jours de vente pour activer une extension de garantie de 2 ans gratuite et recevoir un support technique de qualité gratuit. Pour en savoir plus et vous inscrire.

[ENHANCEgaming.com/warranty](https://www.ENHANCEgaming.com/warranty)

BECOME A VIP



Free Product Giveaways

Exclusive Discounts

Sneak Peek at New Products

And More VIP Perks!

AccessoryPower.com/VIPclub

IN LESS THAN 30 SECONDS

LIKE US ON FACEBOOK



Join Our Community
and Stay Up-To-Date
with News & Promotions

[Facebook.com/AccessoryPower](https://www.facebook.com/AccessoryPower)



Need help with this product?
Besoin d'assistance sur ce produit?
¿Necesita ayuda con este producto?
Benötigen Sie Hilfe bei diesem Produkt?
Hai bisogno di aiuto per questo prodotto?
购买的产品，是否需要提供协助？

[ENHANCEgaming.com/support](https://enhancegaming.com/support)

Package contents
L'emballage contient
Contenidos del paquete
Packungsinhalt
Contenuto della confezione
包装内容

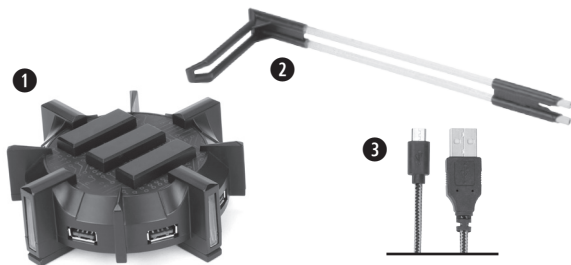

EN

- 1 USB hub base
- 2 Headset stand
- 3 Micro USB cable

FR

- 1 Base de hub USB
- 2 Support casque
- 3 Câble micro USB

ES

- 1 Base hub USB
- 2 Soporte para auriculares
- 3 Cable micro USB

DE

- 1 Standfläche mit USB-Hub
- 2 Headset-Ständer
- 3 Mikro-USB-Kabel

IT

- 1 Base hub USB
- 2 Stand per cuffie
- 3 Micro cavo USB

ZH

- 1 USB集线器基座
- 2 耳机支架
- 3 小型USB电缆

Product diagram
Schéma du produit
Diagrama de product
Producktabbildung
Schema del prodotto
产品图

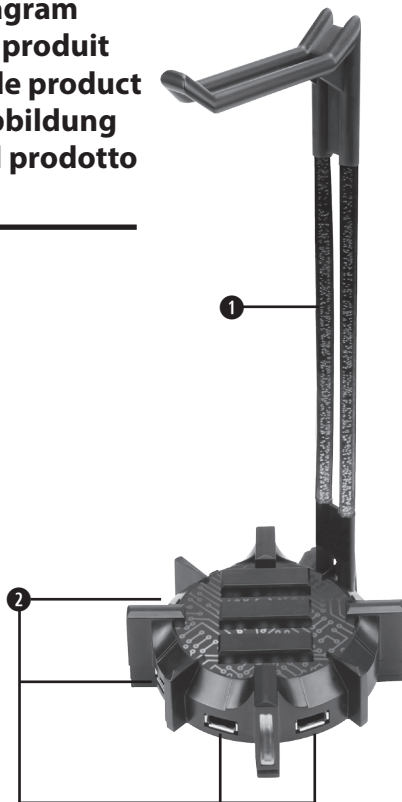

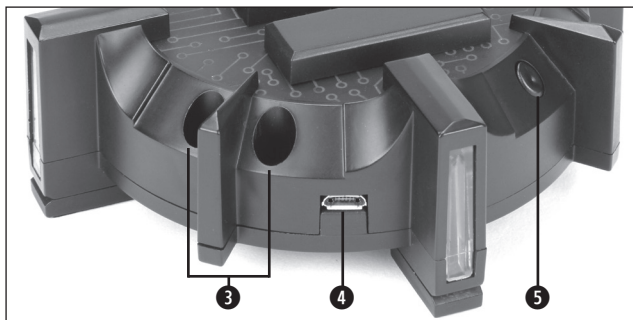

EN	
1	Headset stand
2	4 x USB 2.0 ports
3	Attachment slots
4	USB cable input
5	LED power button

FR	
1	Support casque
2	Quatre ports USB 2.0
3	Fentes de fixation
4	Entrée du câble USB
5	Bouton d'alimentation de la DEL

ES	
1	Soporte para auriculares
2	Cuatro puertos USB 2.0
3	Ranuras de conexión
4	Entrada de cable USB
5	Botón de encendido LED

DE	
1	Headset-Ständer
2	4x USB-2.0-Anschlüsse
3	Steckplätze
4	USB-Kabeleingang
5	LED-Betriebsleuchte

IT	
1	Stand per cuffie
2	4 porte USB 2.0
3	Spazi per attacchi
4	Cavo USB input
5	Pulsante accensione luci LED

ZH	
1	耳机支架
2	4个USB 2.0端口
3	附件插槽
4	USB电缆输入
5	LED电源按钮

Operating instructions

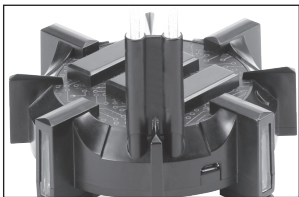
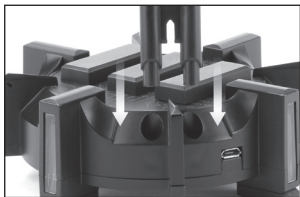

Insert the headset stand into the attachment slots.



Connect to PC using the Micro USB cable. The drivers will install automatically.



Press the LED power button to turn ON lighting or cycle through the 6 different colors and rainbow mode. Press and hold the LED power button for 3 seconds to turn off lighting.



Place your headset on the stand.

NOTE: Headset not included. Do not drop or press down on the headset stand with excessive force.

Mode d'emploi

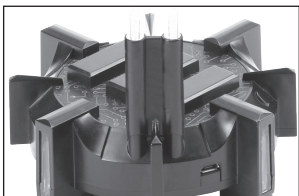
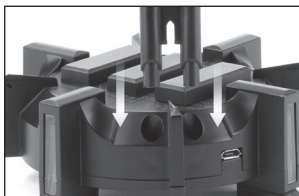

Insérez le support casque dans les encoches de fixation.



Connectez-le au PC à l'aide du câble micro-USB. Les pilotes d'installeront automatiquement.



Appuyez sur le bouton marche LED pour ALLUMER l'éclairage, ou parcourez les 6 différentes couleurs et le mode arc-en-ciel. Appuyez et maintenez enfoncé le bouton marche LED pendant 3 secondes pour éteindre l'éclairage.



Placez votre casque sur le support.

NOTE : Casque non inclus. Ne faites pas tomber le support casque, et n'appuyez pas dessus avec une force excessive.

Instrucciones de Operación

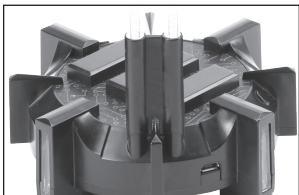
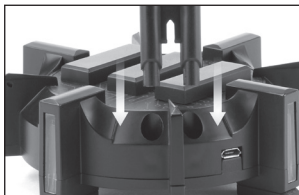

Introduce el soporte de los auriculares en las ranuras del dispositivo.



Conéctalo al ordenador con el cable Micro USB. Los controladores se instalarán automáticamente.



Presiona el botón de encendido del LED para encender la luz o recorre los 6 colores diferentes y el modo arco iris. Mantén presionado el botón de encendido del LED durante 3 segundos para apagar la iluminación.



Coloca los auriculares en el soporte.

NOTA: Auriculares no incluidos. No deje caer ni presione el soporte del auricular con demasiada fuerza.

Bedienungsanleitung

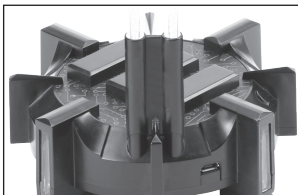
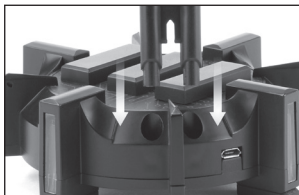

Stecken Sie den Headset-Ständer in die Befestigungsschlitze.



Mit dem PC über das Micro-USB-Kabel verbinden. Die Treiber werden automatisch installiert.

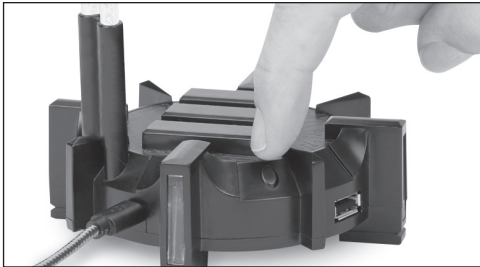

Drücken Sie den LED-Power-Button, um die Beleuchtung EINzuschalten oder durch die sechs verschiedenen Farben und den Regenbogen-Modus durchzublätern. Halten Sie den LED-Power-Button drei Sekunden gedrückt, um die Beleuchtung auszuschalten.



Legen Sie Ihr Headset auf den Ständer.

ANMERKUNG: Headset nicht enthalten. Nicht fallen lassen oder mit übermäßiger Kraft auf den Headset-Ständer drücken.

Istruzioni operative

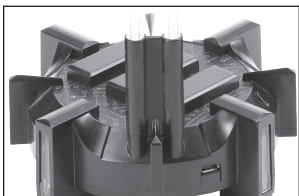
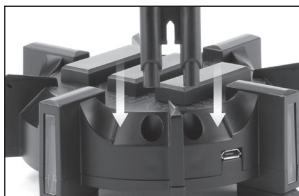

Inserire il supporto per cuffie negli spazi per il fissaggio.



Collegare al PC usando un cavo micro USB. I driver verranno installati automaticamente.



Premere il pulsante d'accensione LED per ACCENDERE l'illuminazione o per alternare i 6 diversi colori e la modalità arcobaleno. Tieni premuto il pulsante d'accensione LED per 3 secondi per spegnere l'illuminazione.



Posiziona le tue cuffie sul supporto.

NOTA: le cuffie non sono incluse. Non premere con troppa forza sullo stand per cuffie.

操作指令

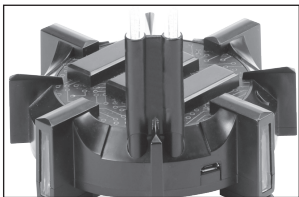
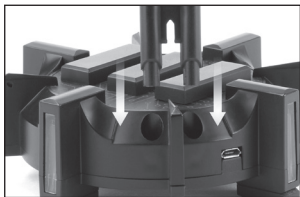

将耳机支架插入附件插槽。



使用数据线连接到电脑。驱动程序会自动安装。



按下 LED 电源按钮打开灯光或在 6 种不同颜色和彩虹模式下循环。按住 LED 电源按钮 3 秒钟以关闭灯光。



将您的耳机放在支架上。
注：耳机不包括在内。请勿抛掷或用力过度按压耳机支架。

WARRANTY GARANTIE GARANTÍA



GARANTIE GARANZIA 保固

This product comes with a 1 year limited warranty, the acceptance of which is a condition of sale. Register this product within 30 days of sale to activate a complimentary 2 year warranty extension and receive free advanced technical support. For warranty program details, registration, and support visit ENHANCEgaming.com/warranty

Ce produit est livré avec une garantie limitée de 1 an, la condition étant l'achat du produit. Enregistrer ce produit dans les 30 jours de vente pour activer l'extension de garantie de 2 ans gratuite et recevoir un support technique de qualité gratuit. Pour les détails du programme de garantie, l'enregistrement, et l'assistance visiter ENHANCEgaming.com/warranty

Product specifications

Spécifications du produit

Especificaciones del producto

Produktspezifikationen

Specifiche del prodotto

产品规格

Power input: 5V \pm 0.5A

USB ports: 4 x USB 2.0

USB power output: 5V \pm 0.5A (MAX)

Data transfer speed: 480Mbps

Power and data cable length: 47.25 inches

Dimensions (with headset hook):

11.25 x 4.62 x 4.62 inches

Weight: 7 ounces

Alimentation électrique: 5V \pm 0,5A

Ports USB: 4 x USB 2,0

Puissance de sortie USB: 5V \pm 0,5A (MAX)

Vitesse de transfert des données: 480 Mbps

Longueur du câble d'alimentation et de données: 120 cm

Dimensions (avec crochet pour casque):

28,57 x 11,73 x 11,73 cm

Poids: 198 g

© 2019 AP Global, Inc. All rights reserved. Accessory Power, the Accessory Power logo, ENHANCE, the ENHANCE logo and other Accessory Power marks and logos are either registered trademarks or trademarks of AP Global, Inc. in the United States and/or other countries. All other trademarks are the property of their respective owners.

Manufactured in China. Designed in California.

© 2019 AP Global, Inc. Tous droits réservés. Accessory Power, le logo Accessory Power, ENHANCE le logo ENHANCE et les autres marques et logos d'Accessory Power sont soit des marques déposées soit des marques de AP Global, Inc. aux États-Unis et/ou dans d'autres pays. Toutes les autres marques sont la propriété de leurs propriétaires respectifs.

Fabriqué en Chine. Conçu en Californie.



[YouTube.com/AccessoryPower](https://www.youtube.com/AccessoryPower)



[Facebook.com/AccessoryPower](https://www.facebook.com/AccessoryPower)



[Instagram.com/AccessoryPower](https://www.instagram.com/AccessoryPower)



HEADSET STAND WITH USB HUB

MODEL NUMBER: ENPCGHH100BKEW

ENHANCEgaming.com/recycle

